

NEW VISION - PARK TRAILER SERIES
 NV-2003 COPPERWOOD LOFT
 11'-8" x 34' BOX (396.7 SF)

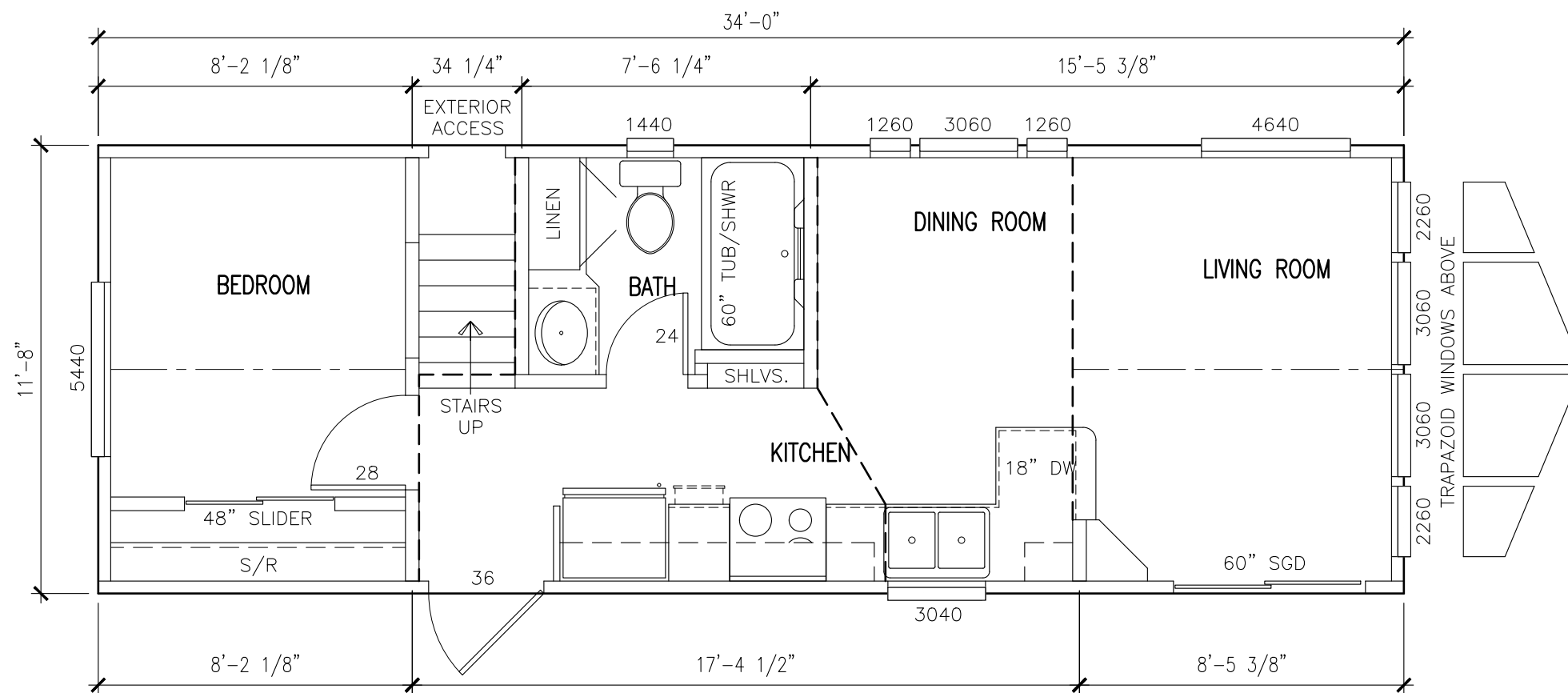
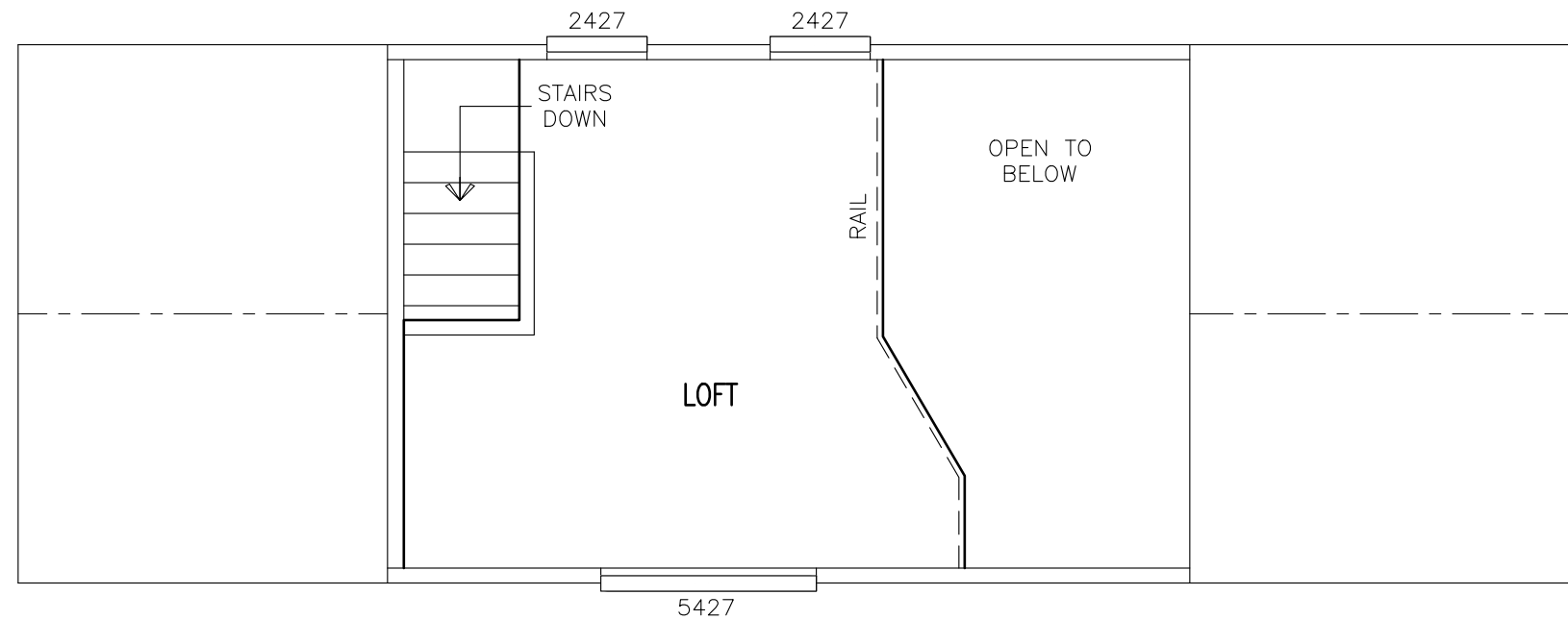

NEW VISION

DATE:
01/13/2023

MODEL:
NV-2003

TITLE:

APPROVAL FLOOR PLAN

DWG #:
FP-2003.1

SCALE:
1/4" = 1'-0"

DRAWN BY:
NEBD

REF # DESCRIPTION

DATE

REVISED BY:

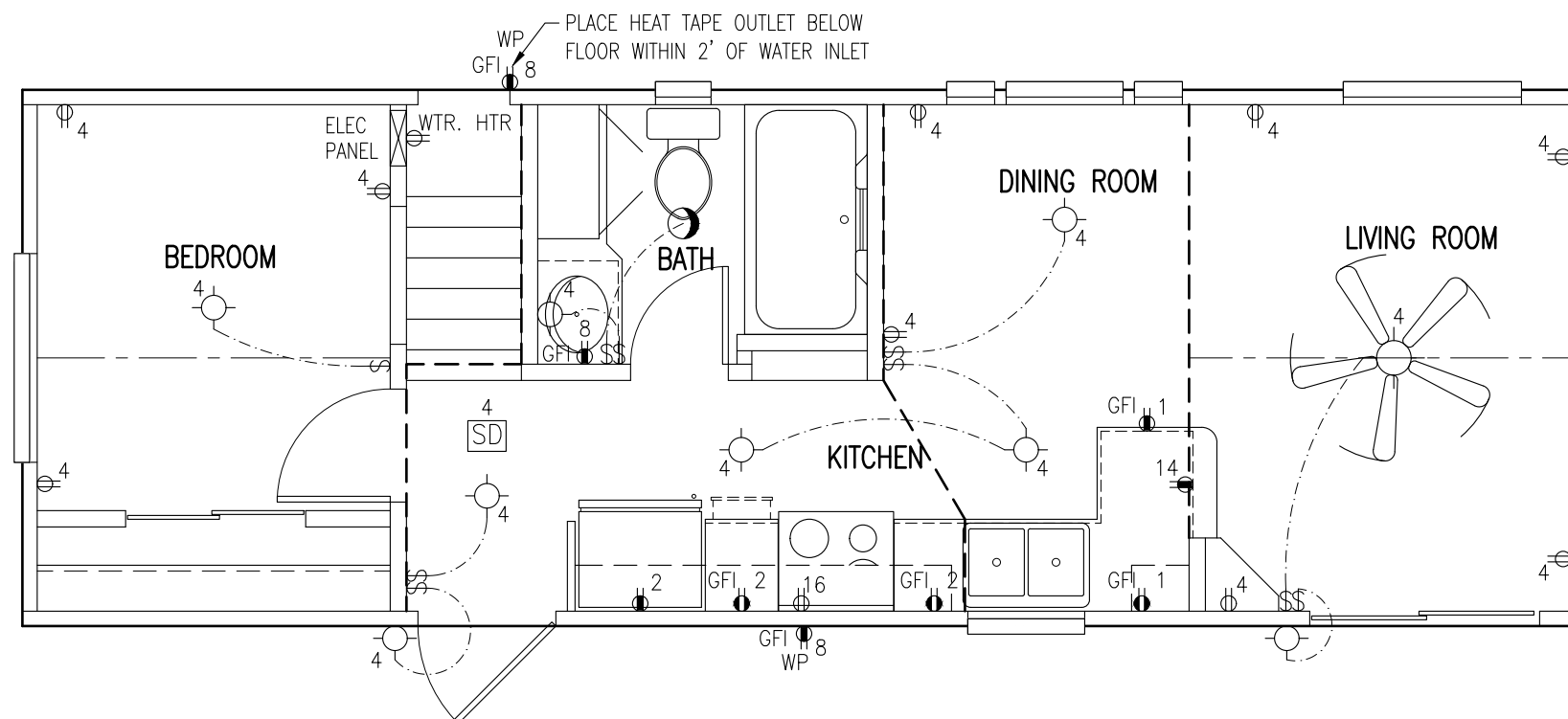
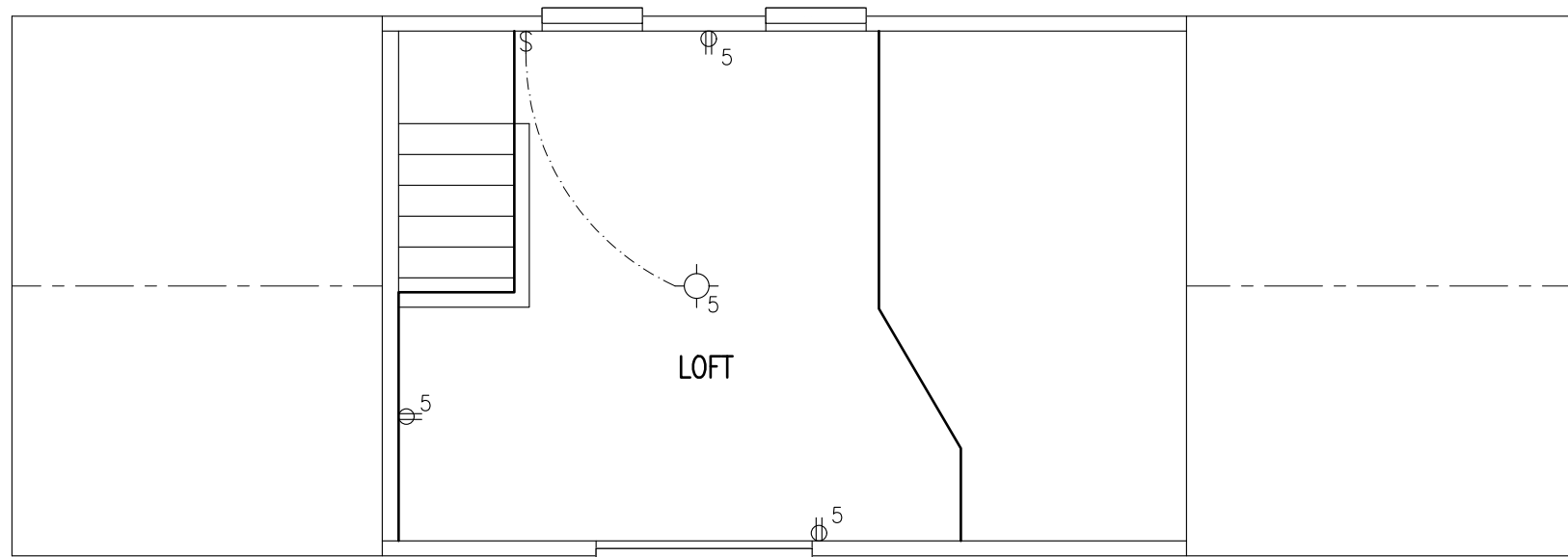

- NOTES:
1. SEE FP-2 FOR ELECTRICAL SCHEDULE AND SYMBOL SCHEDULE.
 2. ELECTRICAL INSTALLATIONS SHALL BE IN ACCORDANCE WITH NFPA-70 NEC 2005.
 3. ISLAND OUTLETS ARE TO BE PLACED WITHIN 6" OF THE SURFACE OF THE COUNTERTOP.

NEW VISION

DATE:
01/13/2023

MODEL:
NV-2003

TITLE:

ELECTRICAL PLAN

DWG #:
FP-2003.2

SCALE:
1/4" = 1'-0"

DRAWN BY:
NEBD

REF # DESCRIPTION

DATE

REVISED BY:

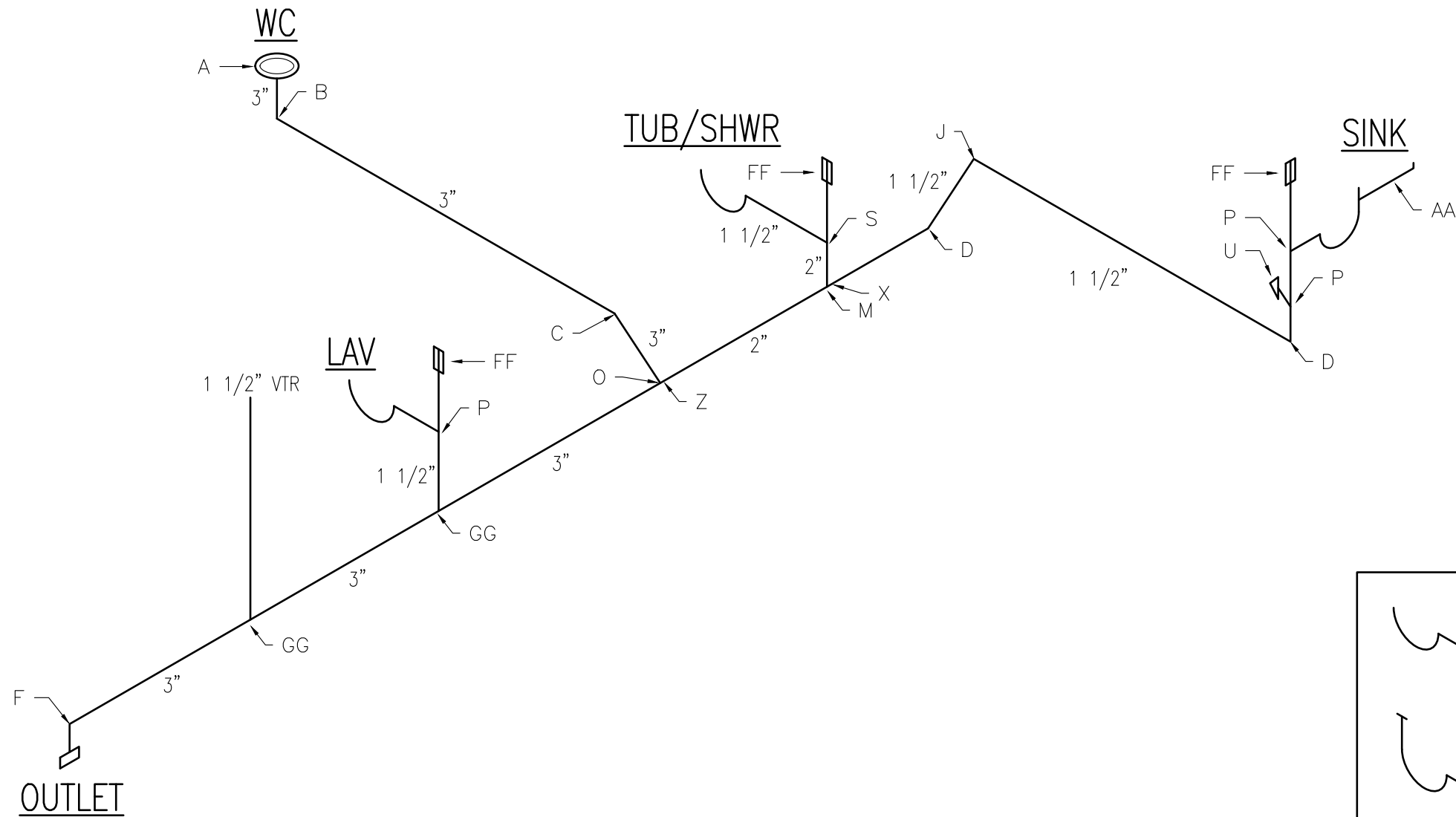

SCHEDULE

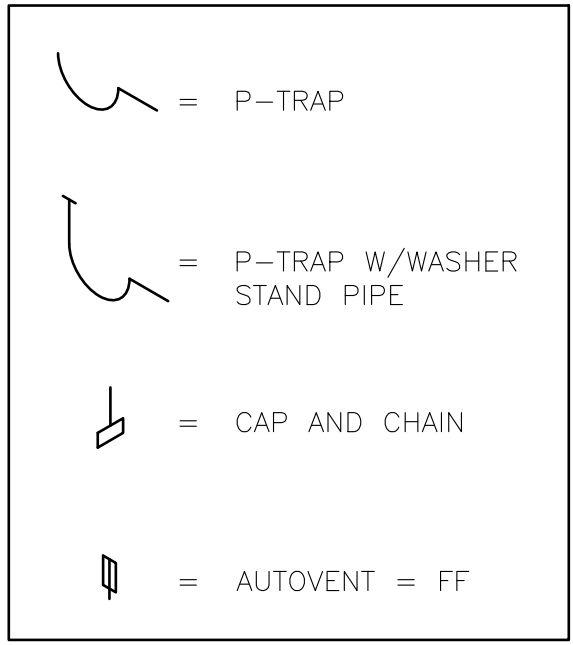

- NOTES:**
1. PIPING SHALL BE SUPPORTED TO PROVIDE 1/4" PER FOOT SLOPE, MINIMUM SLOPE IS 1/8" WITH FULL SIZE CLEAN-OUT AT THE UPPER END.
 2. ALL LINES 1 1/2" UNLESS OTHERWISE NOTED.
 3. SEE PAGE PL-9 FOR FITTING SCHEDULE.

NEW VISION	DATE: 01/13/2023	MODEL: NV-2003	DRAIN-WASTE-VENT			DWG #: FP-2003.3
	SCALE: NONE	DRAWN BY: NEBD	REF #	DATE	REVISED BY:	

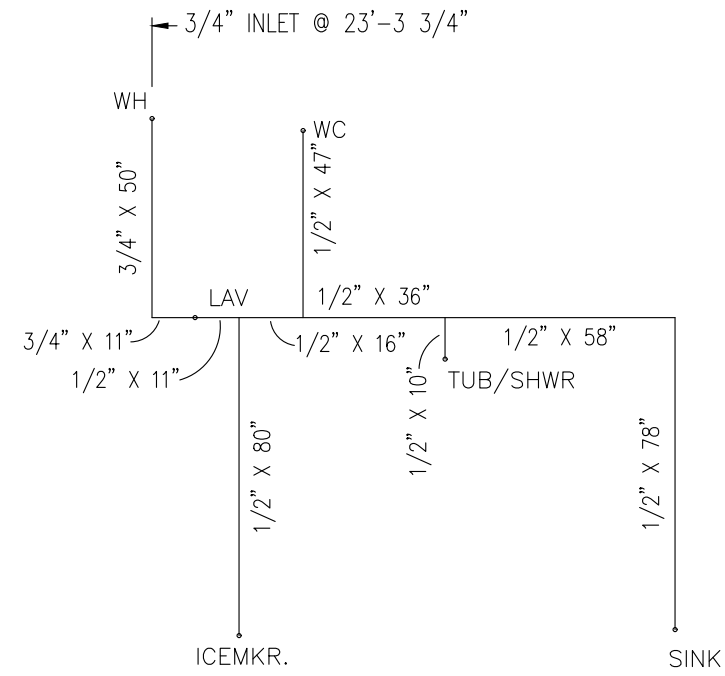

COLD WATER

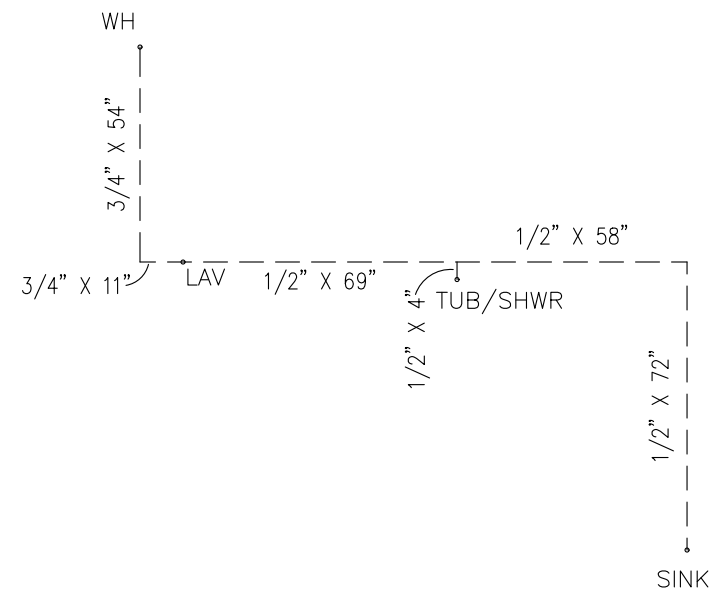

HOT WATER

NEW VISION

DATE:
01/14/2023

MODEL:
NV-2003

WATER SYSTEM — PLAN VIEW

DWG #:
FP-2003.4.1

SCALE:
NONE

DRAWN BY:
NEBD

DATE

REVISED BY:

-

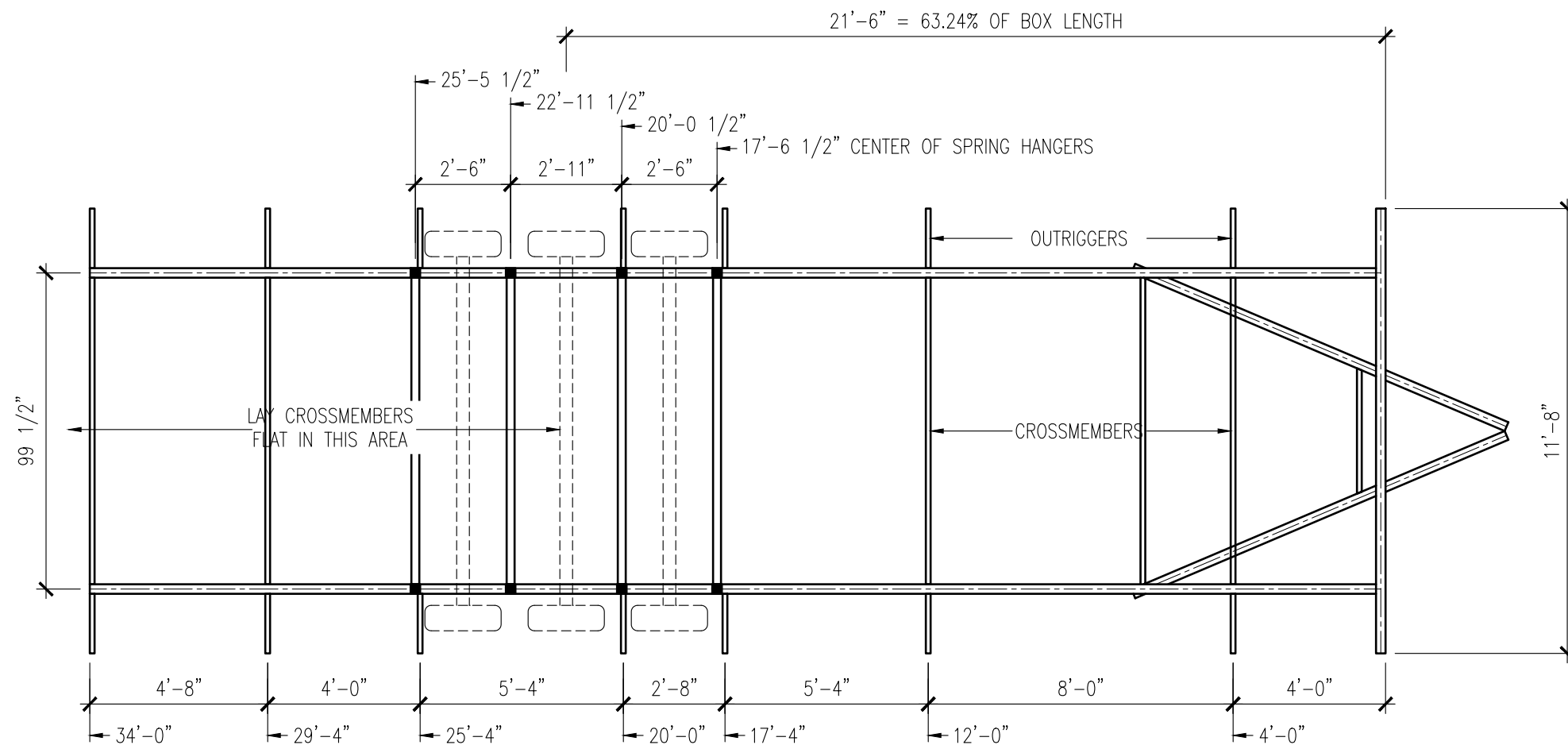

NOTES:

1. THIS DRAWING IS BASED ON THE DAPIA PACKAGE AND MAY NOT TAKE IN TO CONSIDERATION ALL DYNAMIC FORCES INDUCED ON THE CHASSIS WHILE IN MOVEMENT. PLEASE REVISE AFTER AN ACCURATE WEIGHT IS DETERMINED AND THE TRANSPORTATION TEST IS COMPLETED, IF REQUIRED.
2. SEE DAPIA PAGES CH-3.0, CH-15 AND FL-1 FOR INFORMATION USED TO DESIGN THIS CHASSIS.

NEW VISION

DATE:
01/13/2023
SCALE:
3/16" = 1'-0"

MODEL:
NV-2003
DRAWN BY:
NEBD

TITLE:

CHASSIS

DWG #:
FP-2003.CH

REF #	DESCRIPTION
-	-

DATE

REVISED BY:

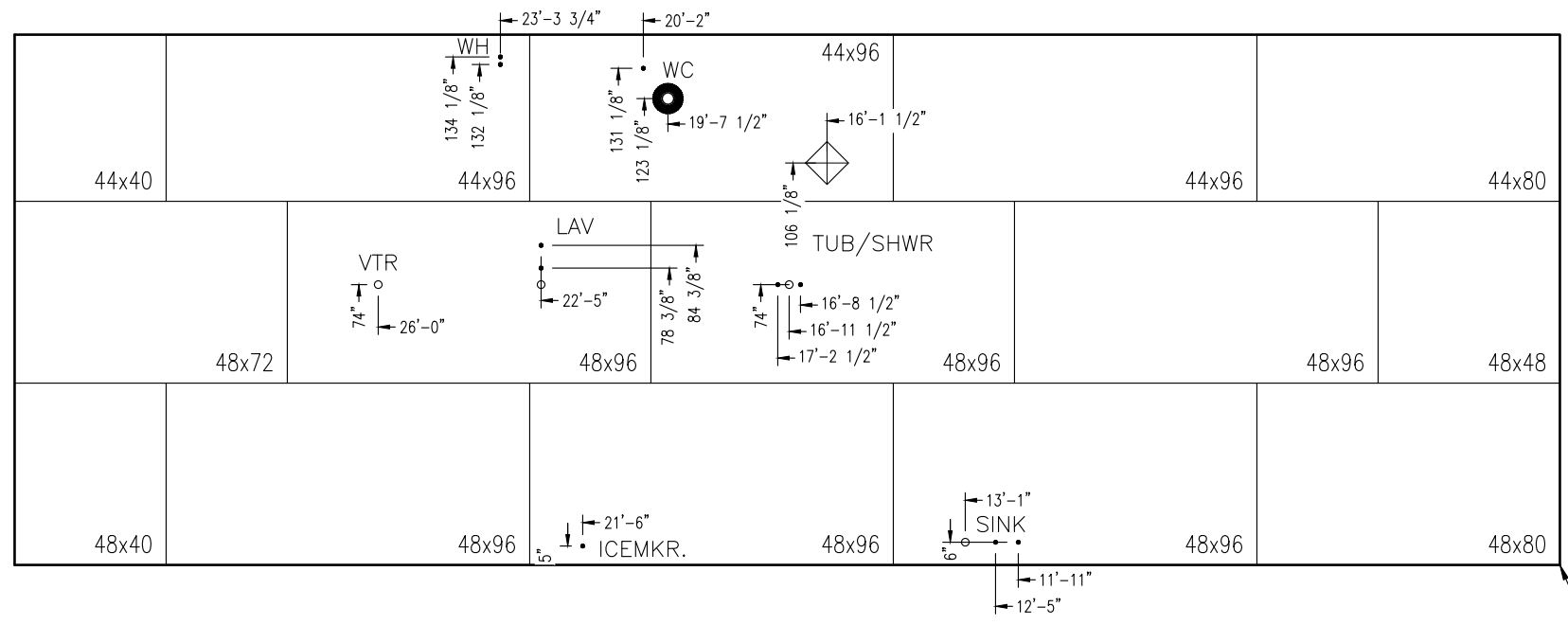
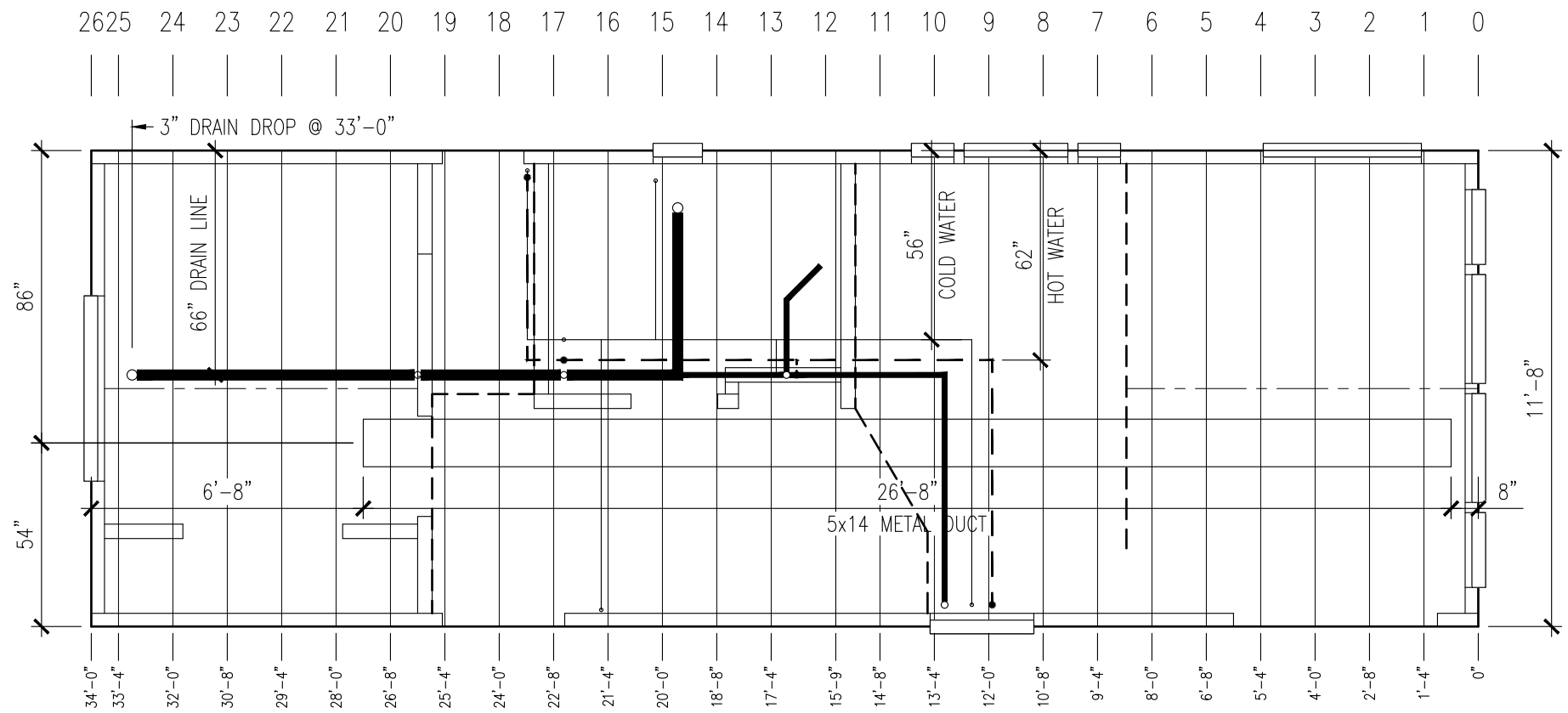

- HOLE LEGEND**
- WATER CLOSET (5")
 - DWV/VENT (2 1/2")
 - WATER OR WIRE (1")
 - ◇ P-TRAP (8" SQUARE)

HOLE DIMENSION FROM THIS LOCATION

NEW VISION

DATE: 01/13/2023	MODEL: NV-2003	TITLE: FLOOR FRAMING & DECKING	DWG #: FP-2003.1.1
SCALE: 1/4" = 1'-0"	DRAWN BY: NEBD	REF # DESCRIPTION	DATE
		- -	-
			REVISED BY:
			-

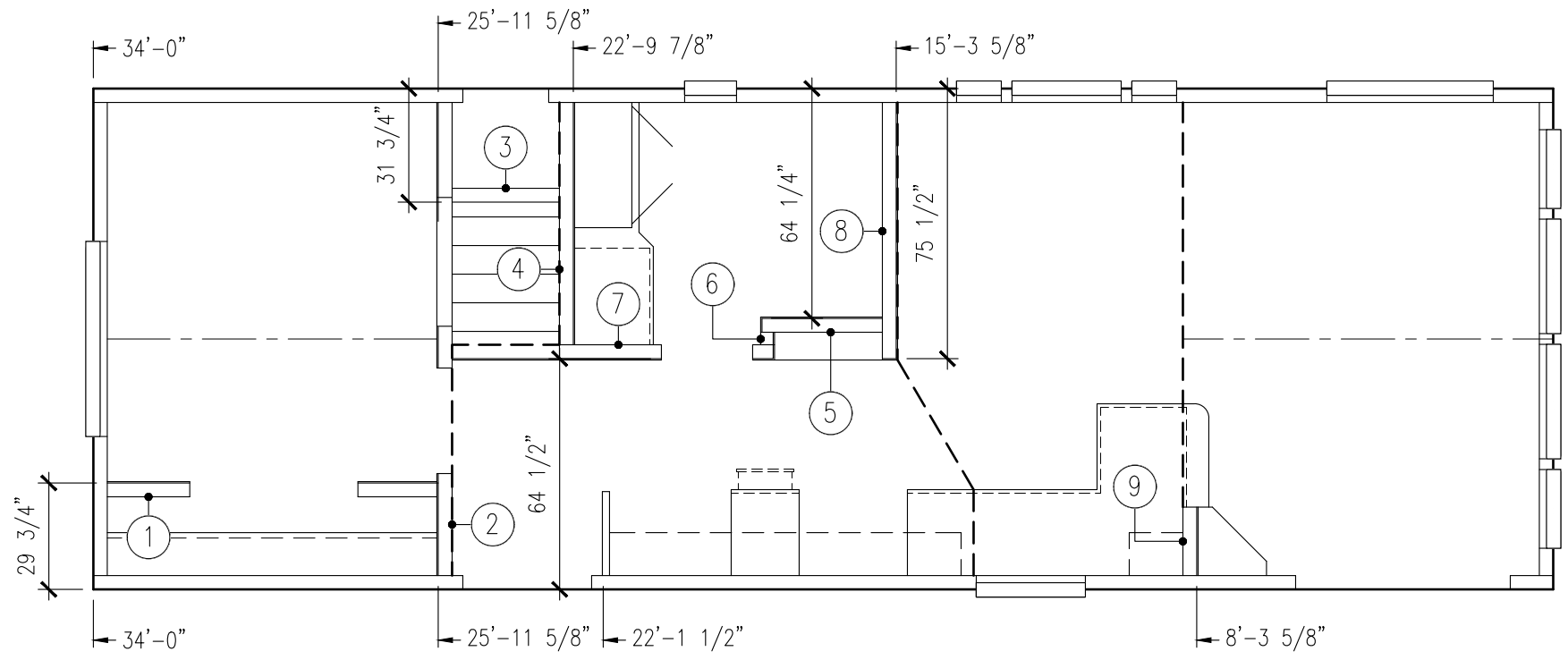

NEW VISION

DATE:
01/13/2023

MODEL:
NV-2003

TITLE:

CABINET & WALL SET

DWG #:
FP-2003.WS

SCALE:
1/4" = 1'-0"

DRAWN BY:
NEBD

REF # DESCRIPTION

DATE

REVISED BY:

REF #	DESCRIPTION	DATE	REVISED BY:

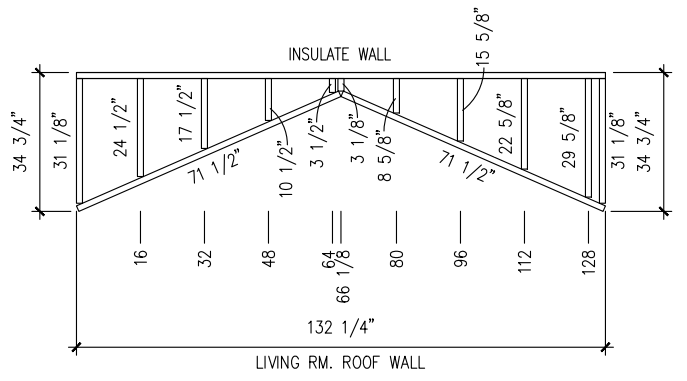
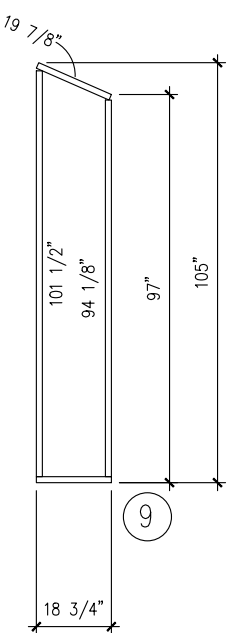
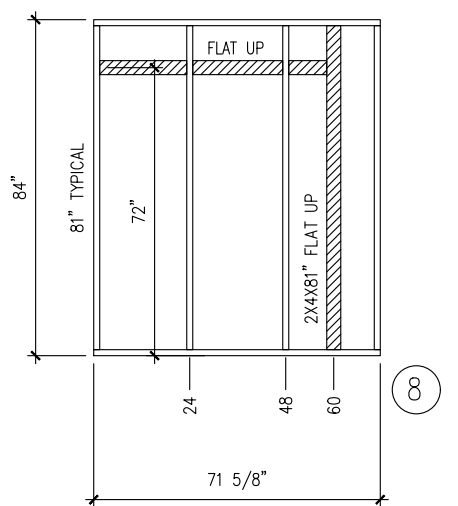
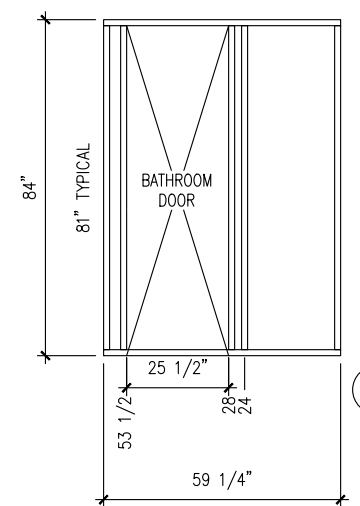
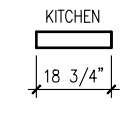
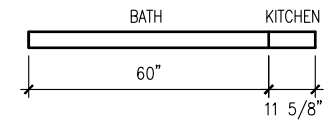
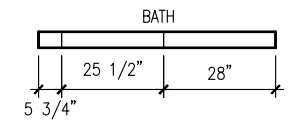
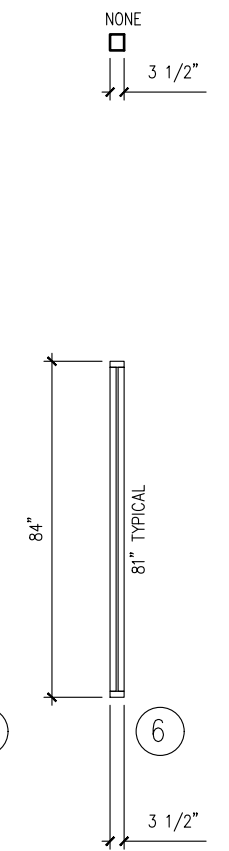
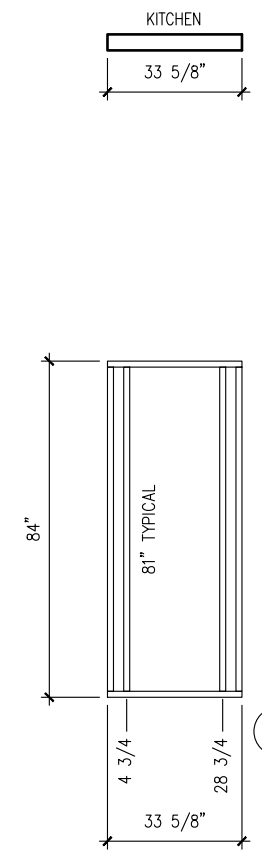
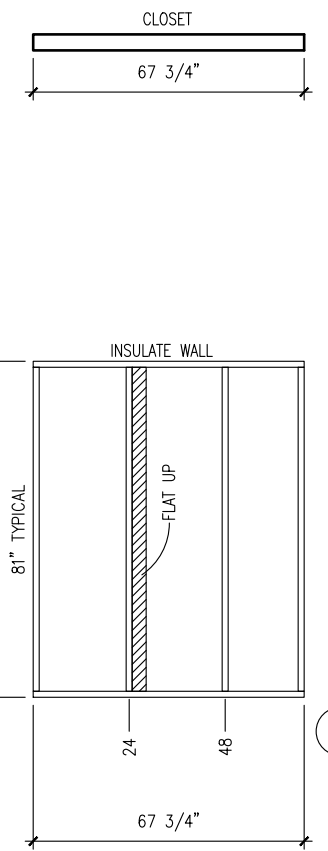
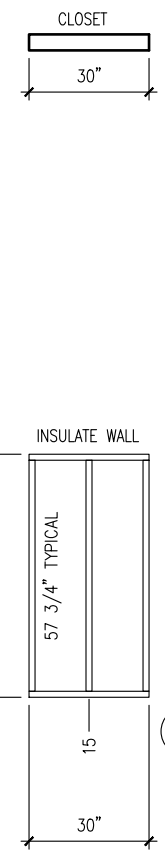
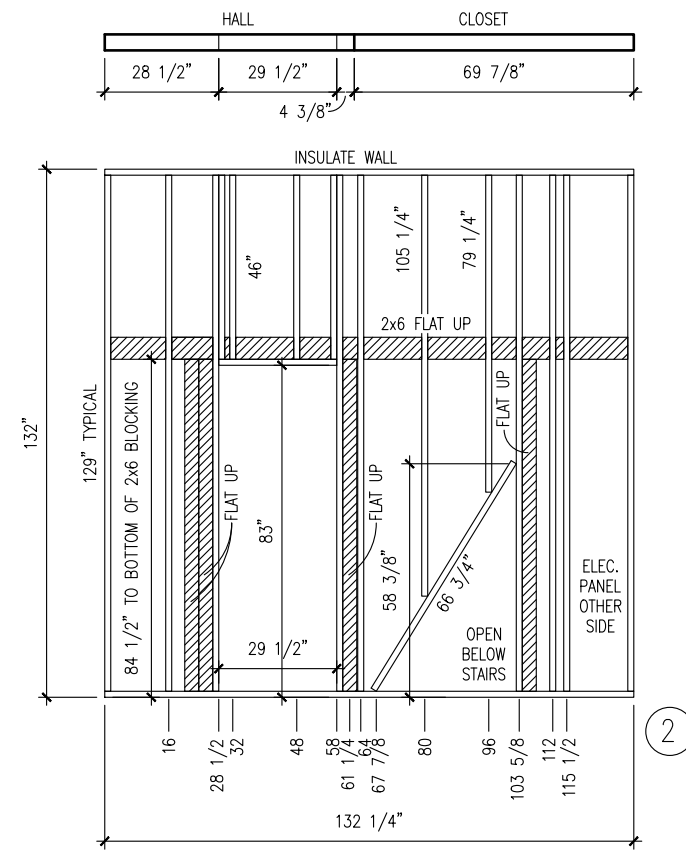
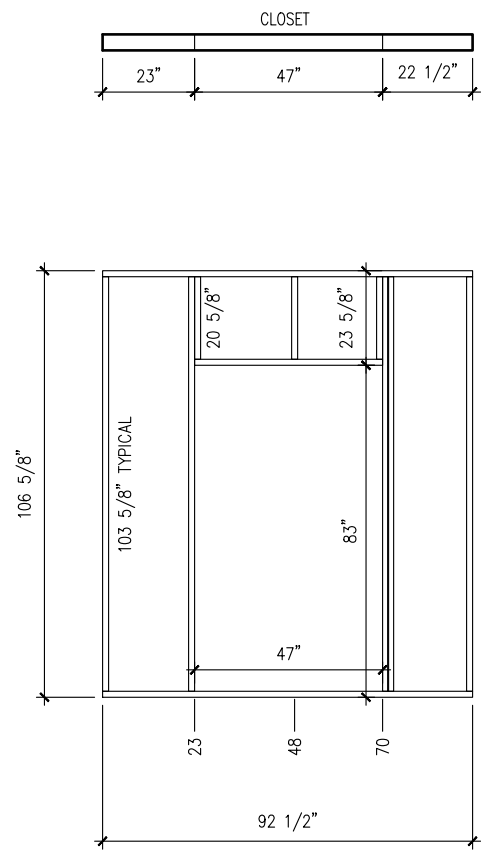

NEW VISION

DATE:
01/13/2023
SCALE:
1/4" = 1'-0"

MODEL:
NV-2003
DRAWN BY:
NEBD

TITLE:		DATE	REVISED BY:
PARTITIONS - 1			
REF #	DESCRIPTION		

DWG #:
FP-2003.PW1

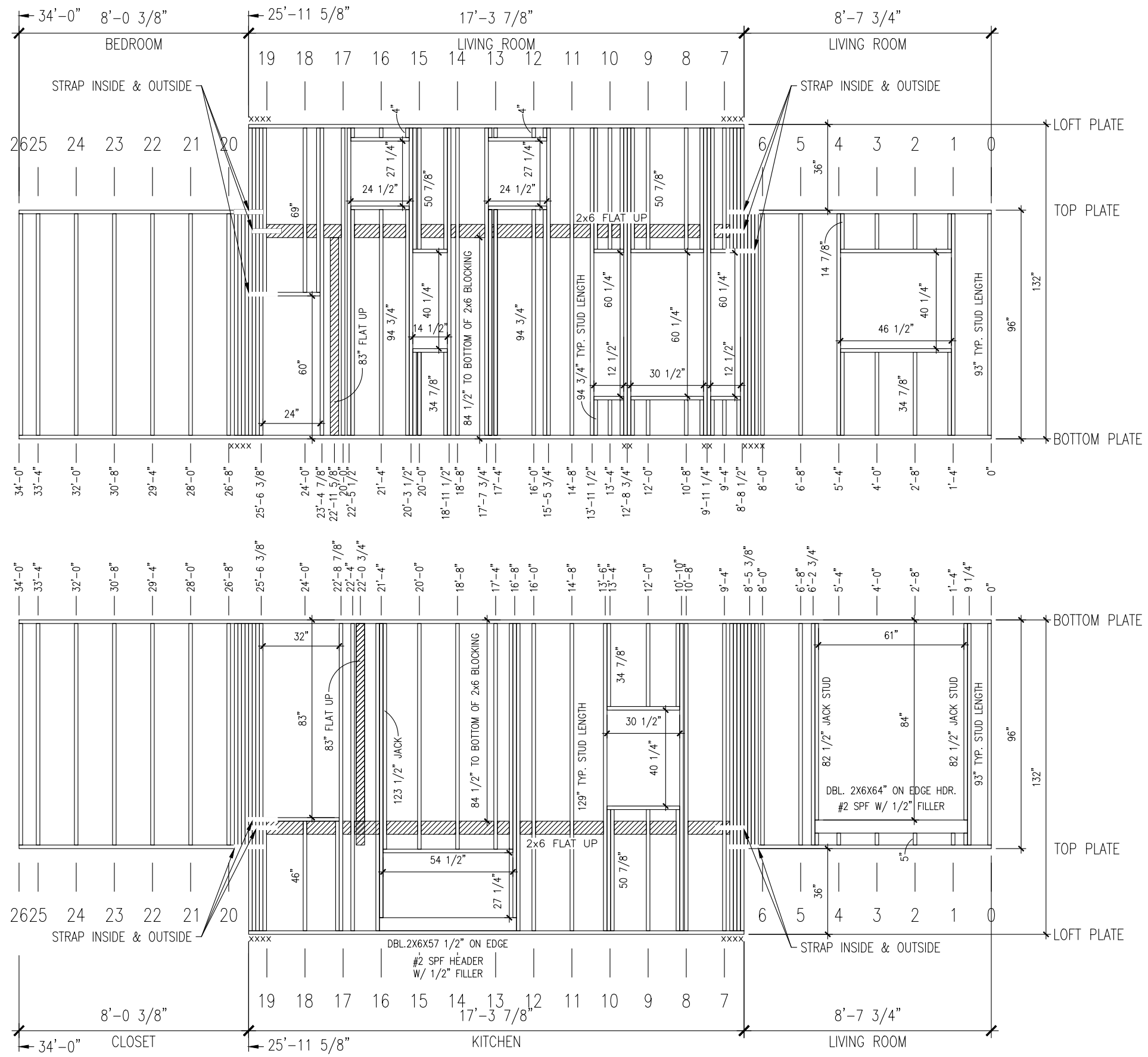

NEW VISION

DATE: 01/14/2023
SCALE: 1/4" = 1'-0"

MODEL: NV-2003
DRAWN BY: NEBD

TITLE: SIDEWALLS		DATE	REVISED BY:
REF #	DESCRIPTION		

DWG #: FP-2003

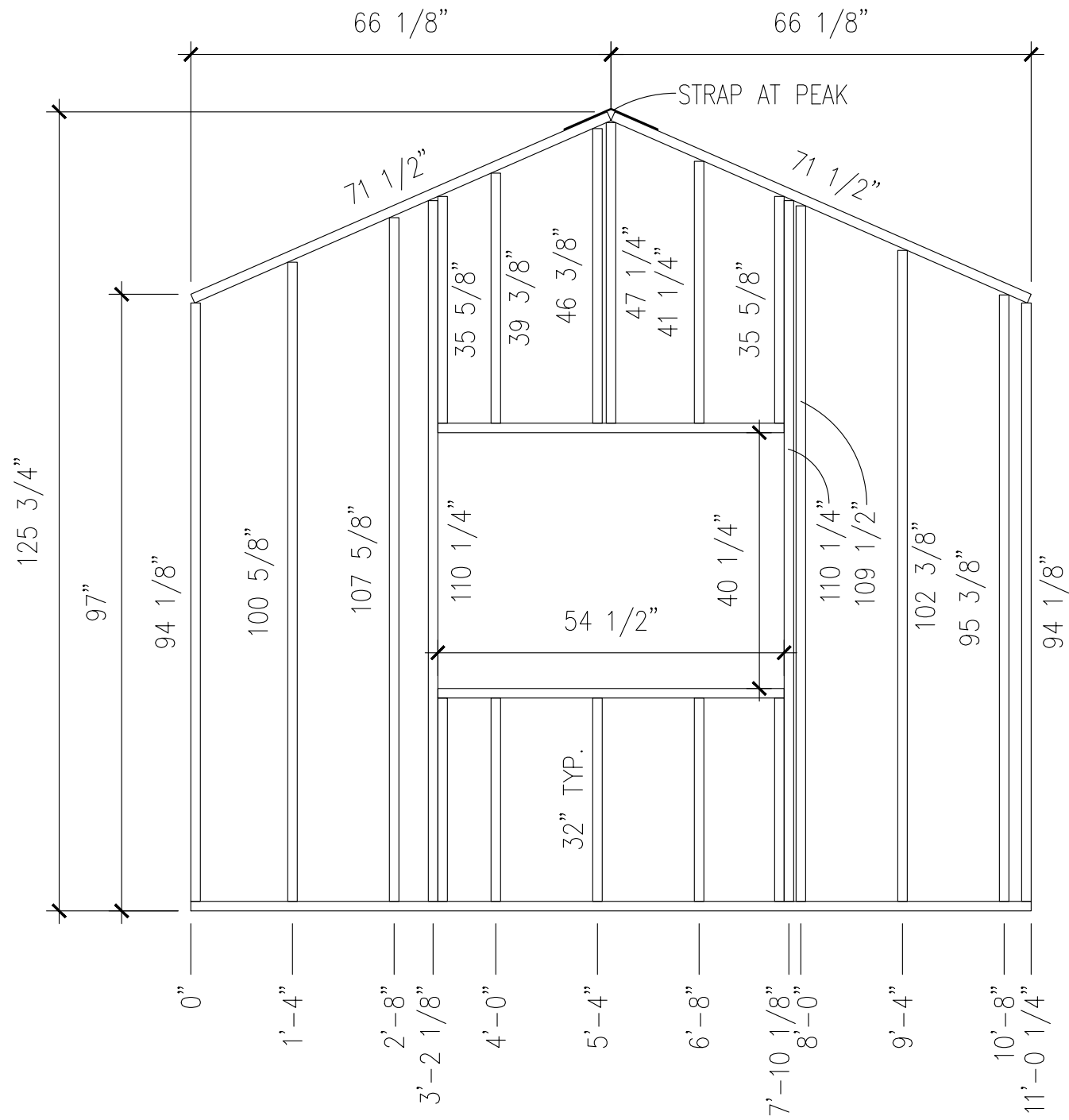

REAR ENDWALL

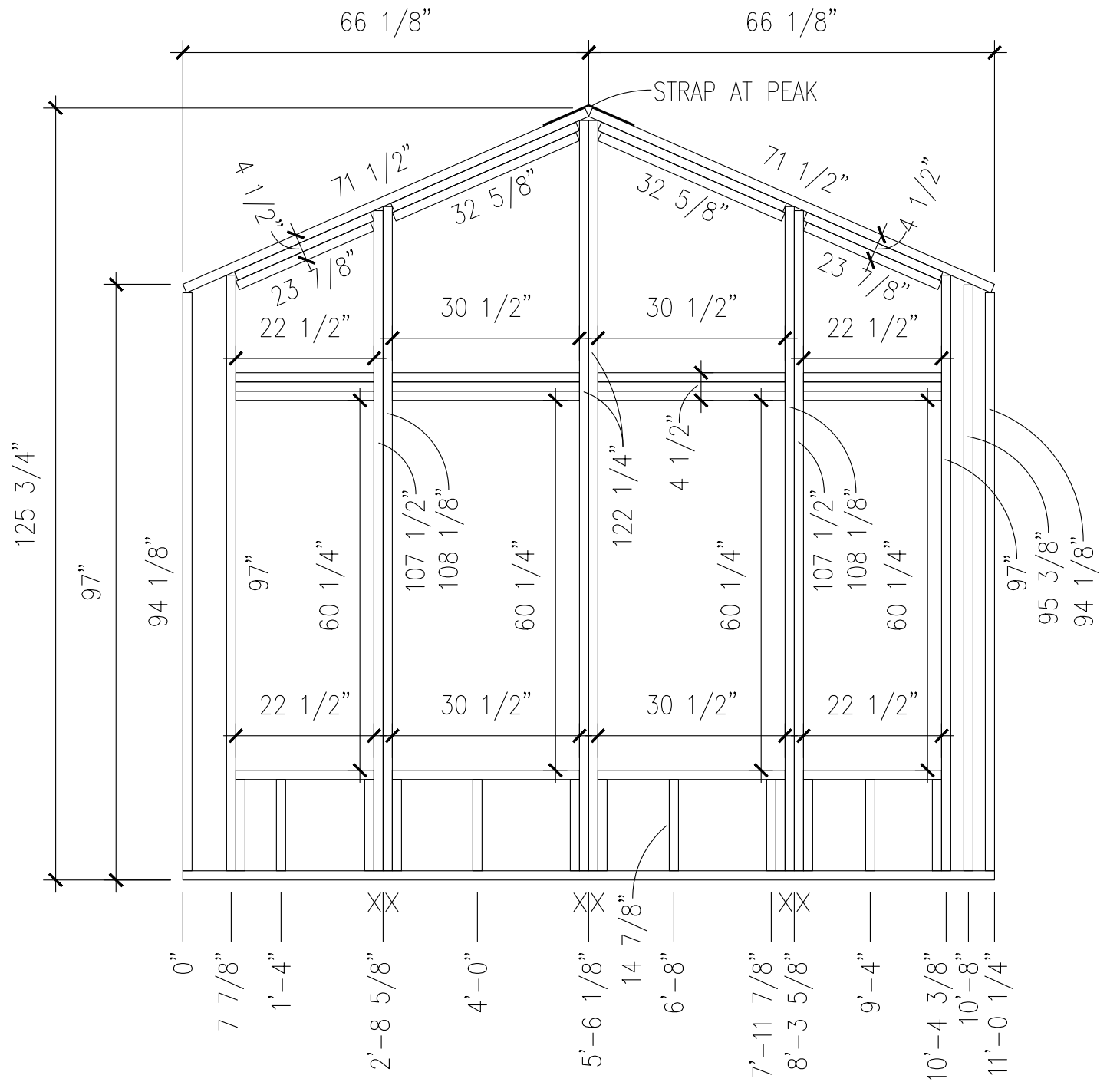

FRONT ENDWALL

NEW VISION

DATE:
01/30/2018

MODEL:
NV-2003

TITLE:

ENDWALLS

DWG #:
FP-2003

SCALE:
1/2" = 1'-0"

DRAWN BY:
NEBD

REF # DESCRIPTION

DATE

REVISED BY:

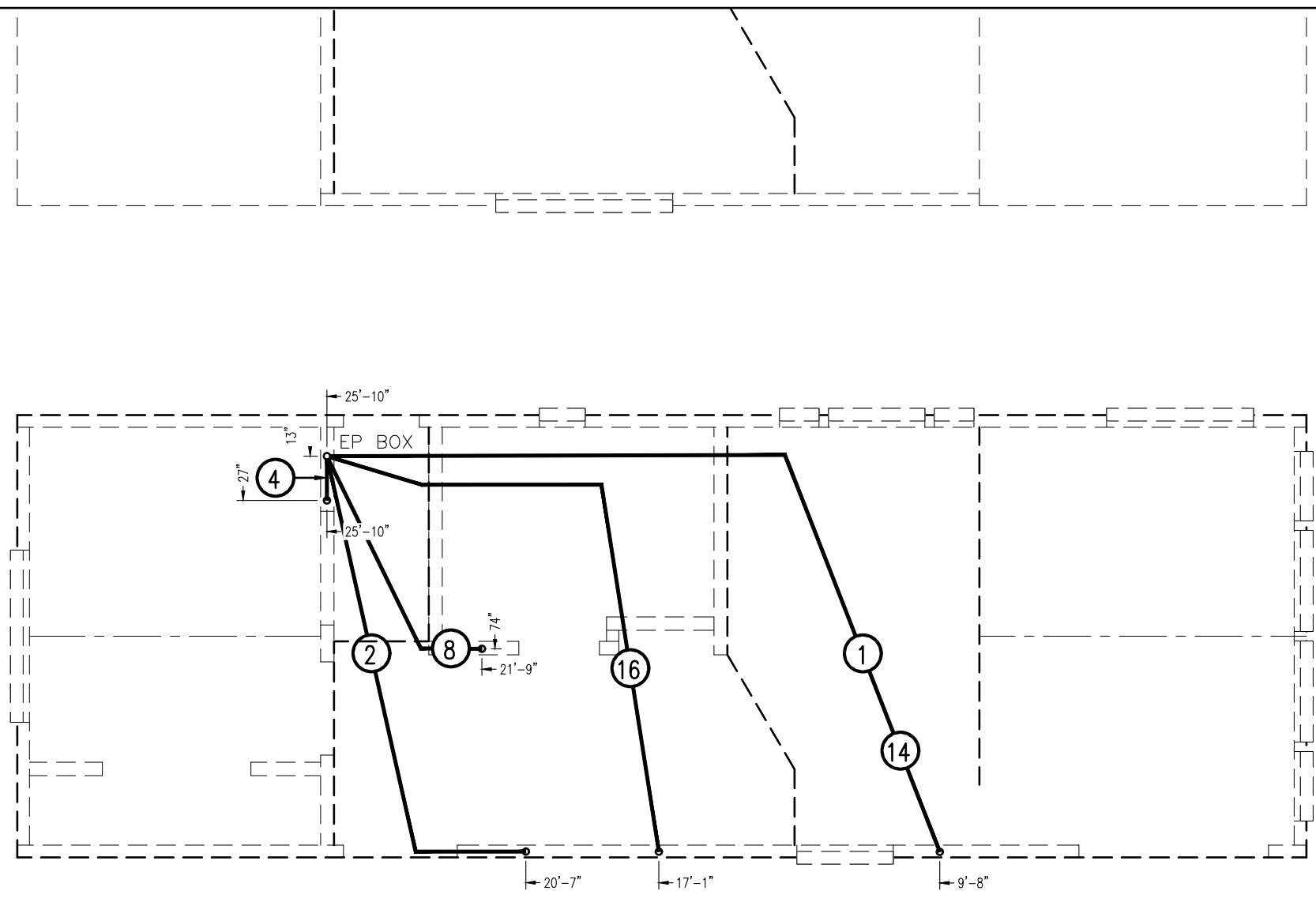

NEW VISION

DATE:
01/14/2023

MODEL:
NV-2003

TITLE:

ROUGH WIRE FLOOR

DWG #:
FP-2003.2

SCALE:
1/4" = 1'-0"

DRAWN BY:
NEBD

REF #	DESCRIPTION	DATE

DATE	REVISED BY:

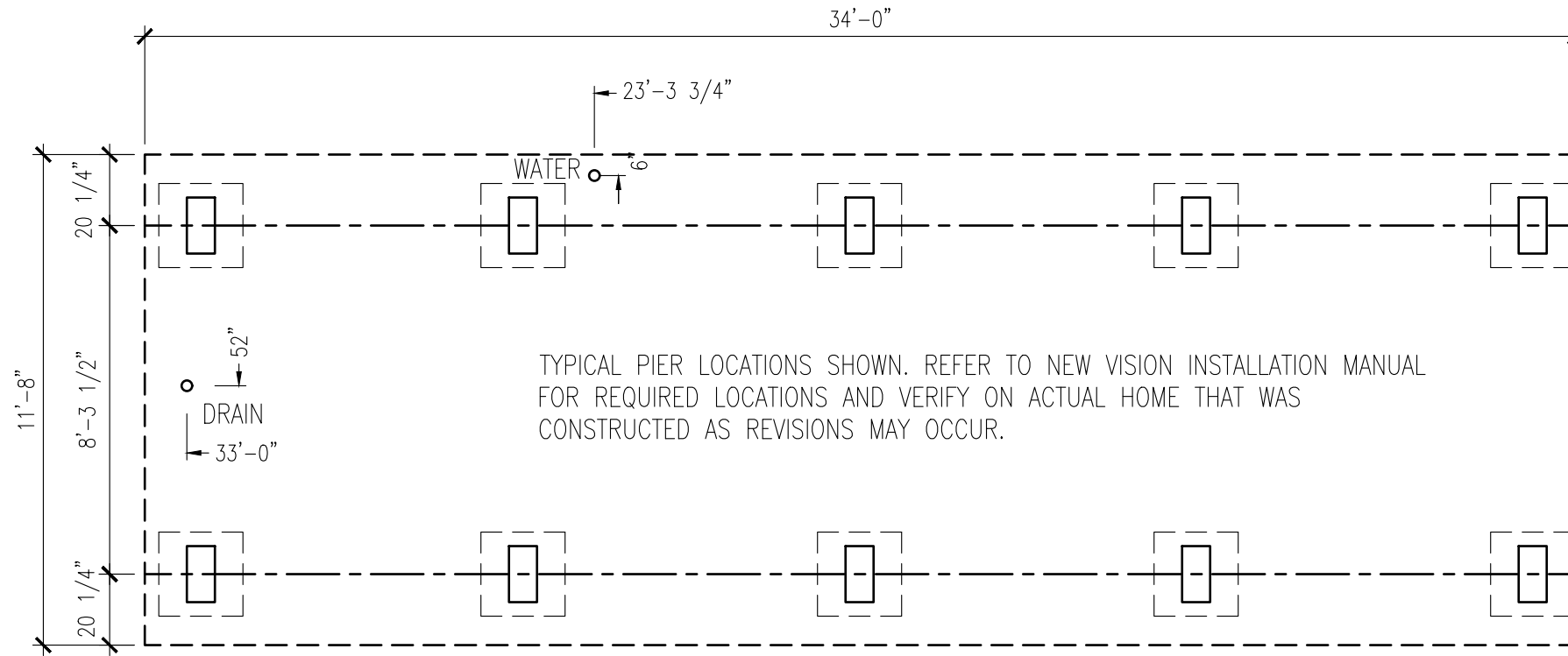

NEW VISION

DATE:
01/18/2023

MODEL:
NV-2003

TITLE:

UTILITY DROP PLAN

DWG #:
FP-2003.UD

SCALE:
1/4" = 1'-0"

DRAWN BY:
NEBD

REF #	DESCRIPTION
-	-

DATE

REVISED BY:

-

-

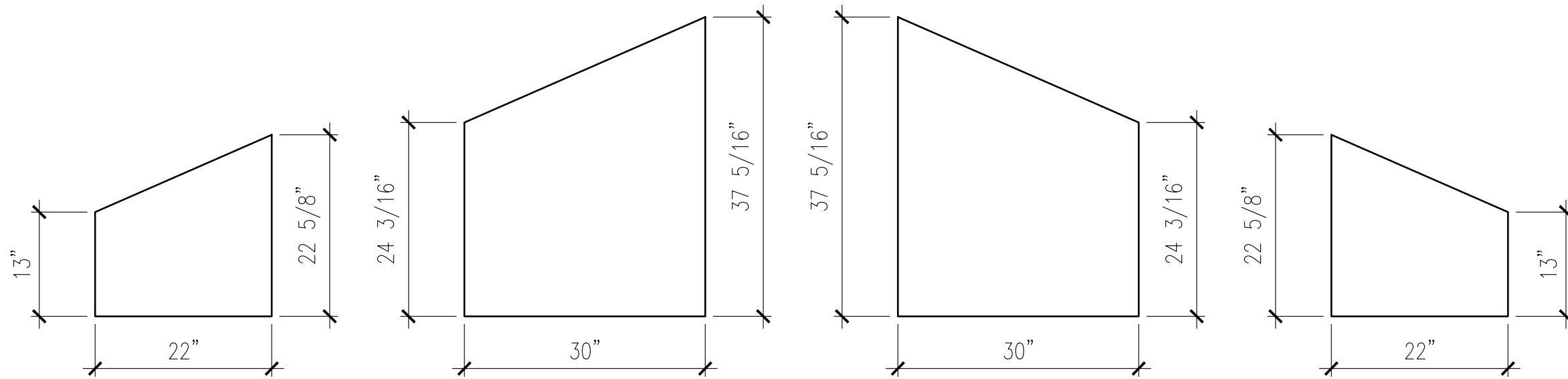

NEW VISION

DATE:
01/13/2023

MODEL:
NV-0000

TITLE:
TRAPEZOID WINDOWS

DWG #:
FP-0000.0

SCALE:
3/4" = 1'-0"

DRAWN BY:
NEBD

REF #	DESCRIPTION	DATE
-	-	-

REVISD BY:
-

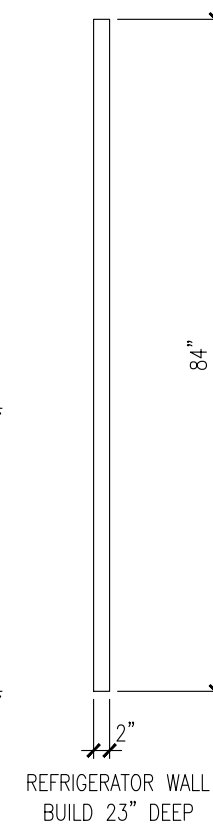
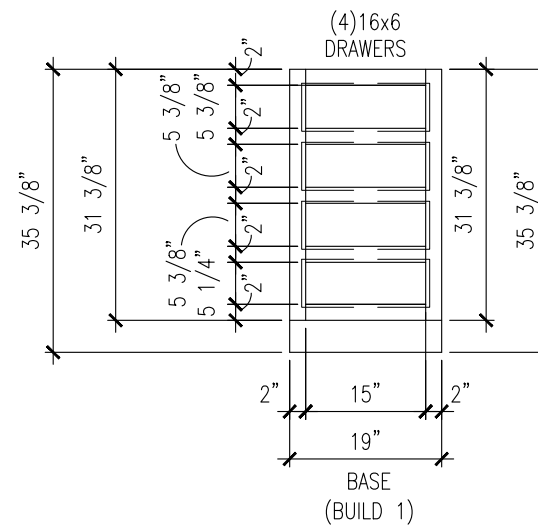
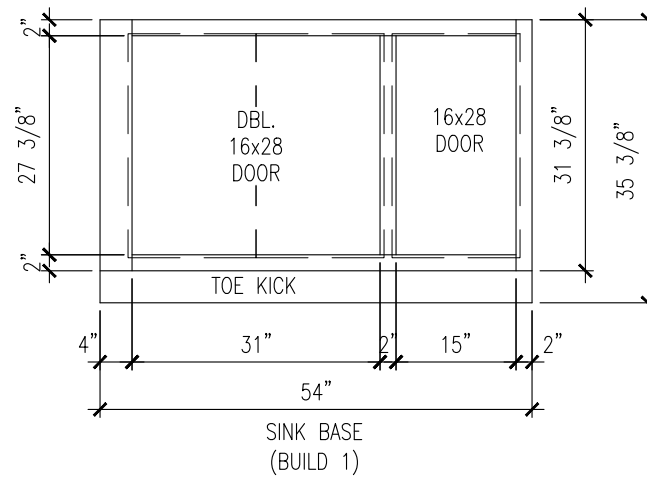
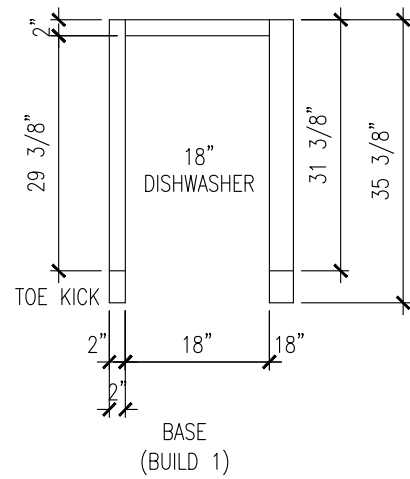
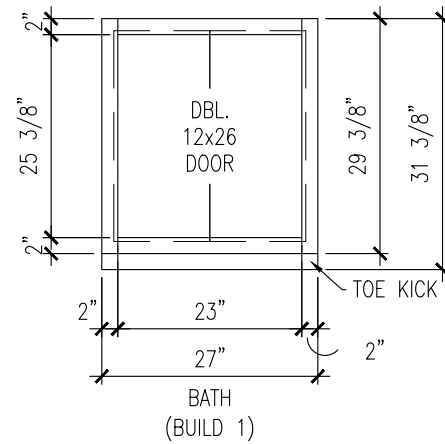
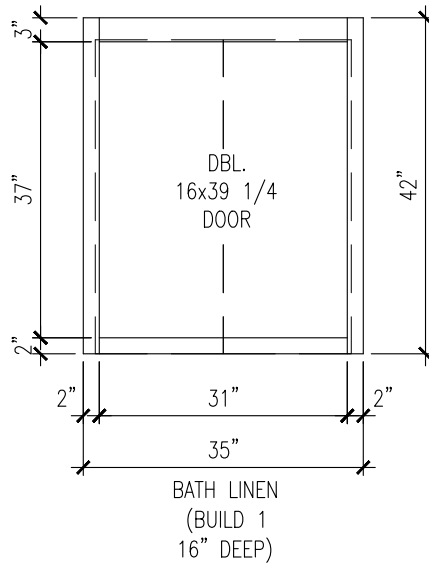

NEW VISION

DATE:
01/18/2023
SCALE:
1/2" = 1'-0"

MODEL:
NV-2003
DRAWN BY:
NEBD

TITLE:

CABINET FACE FRAMES

DWG #:
FP-2003.CAB

REF #	DESCRIPTION	DATE	REVISED BY:
-	-	-	-

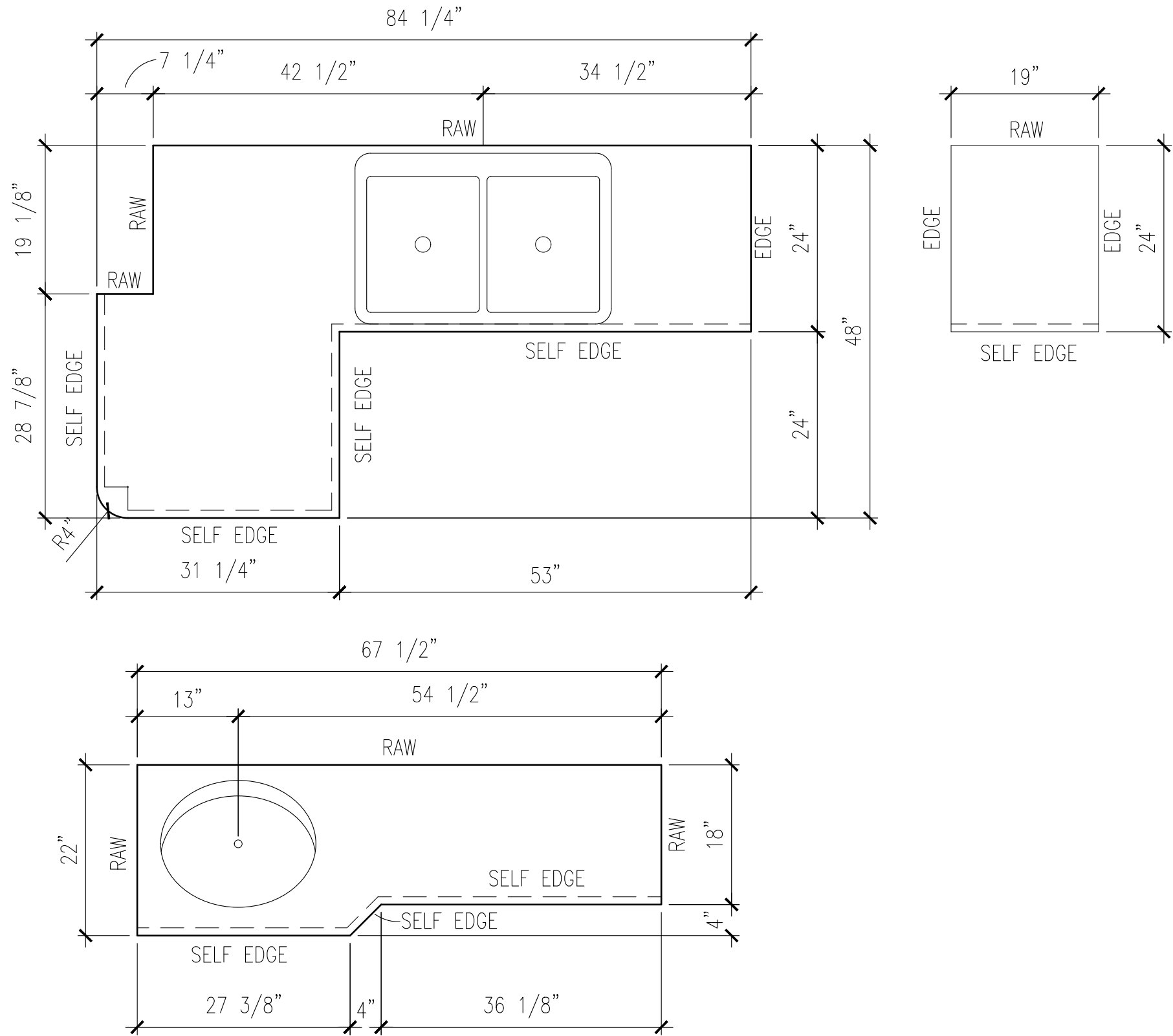

NEW VISION

DATE:
01/18/2023

MODEL:
NV-2003

TITLE:
COUNTER TOPS

DWG #:
FP-2003.TOPS

SCALE:
3/4" = 1'-0"

DRAWN BY:
NEBD

REF #	DESCRIPTION	DATE	REVISED BY:
-	-	-	-